



### EPD32-FD

## 32" Solar Powered Wireless E Ink Poster

The revolutionary Agile Display Solutions EPD32-FD (Forever Display™) is the first full-color digital display that requires no maintenance whatsoever. Using Spectra™ 6 technology from E Ink, it attaches to a wall or shelf as easily as a poster. Hang one, dozens, or thousands of displays, with no cables required, and never touch them again.

A top-mounted solar array powers the display indefinitely under normal store lighting. Control all of them and schedule content simply and wirelessly from your central office, using an easy-to-use web interface or standard API commands. Setting up each display requires less than 5 minutes using a mobile app available on Apple's App Store or Google's Play Store. The future of retail display technology has truly arrived.

### Key Features

- **No Cables or Battery Charging Required**

  - Hang once, never touch again
  - Place in aisles, endcaps or areas where digital signage was previously impractical
  - Significantly reduces installation cost vs. LCD
  - Eliminates labor and improves ROI
- **The Most Sustainable Signage Solution, Period**

  - No printing, no errors, no shipping, no waste
  - Consumes no electricity whatsoever
  - Eliminates battery waste in landfills
  - Advances your company's ESG objectives
- **Easy Set Up and Control**

  - Quickly set up displays using EPD Tool™ mobile app
  - Precisely schedule when content appears on screen
  - Auto-change content by time of day or day of week
- **Compatible with your Network**

  - Choose whether to use the CloudPoster website, or use standard API commands to control displays from your existing CMS system
- **Cutting-edge E Ink Spectra 6 technology**

  - 2560x1440 resolution, 65,000 colors
  - Renowned sheen and legibility of ePaper

## EPD32-FD 32" Solar Powered Wireless E Ink Poster

DISPLAY	
Size	31.5"
Resolution	2560x1440 Pixels
Finish	Matte Reflective (Paper-Like)
Pixel Density	93 PPI
Colors	65,000 Colors
Time To Change Image	approx. 18 Seconds
Portrait/Landscape	Mount Horizontally or Vertically
Construction	Aluminum
Mounting	100 x 100 VESA or D-Ring Picture Hangers
PROCESSING	
CPU	ARM A55 Quad Core
Storage	16 GB
Controls	On/Off, Image Select
Firmware Updates	Automatic Over-the-Air (OTA) Updates
CONNECTIVITY	
Wireless Connectivity	Wi-Fi
Supported File Formats	BMP, PNG, JPG, JFIF
Playlist Scheduling	By date, time of day, or day of week
System Monitoring	Control and monitoring using CloudPoster website or API commands
Provisioning and Setup	Using EPD Tool™ mobile app (iOS and Android)
POWER	
Battery Type	Rechargeable Lithium Ion
Nominal Battery Life	Unlimited battery life under normal store lighting*
ENVIRONMENTAL	
Operating Temperature	0 – 50 C
Operating Humidity	20 - 80% RH
DIMENSIONS	
Dimensions	428.9 x 722.1 x 40.2 mm (16.9 x 28.4 x 1.58 in)
Weight	4 kg / 8.8 lbs

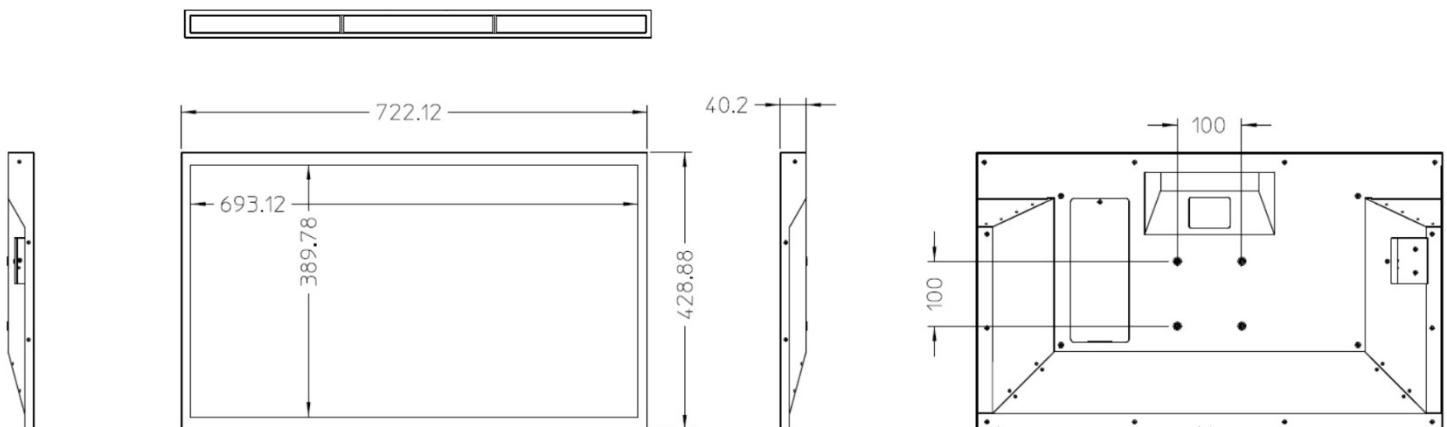

VESA SCREW M6\_15\*4pcs

Specifications subject to change

\*Requires 1000 lux @ 12 hrs/day for unlimited battery life